

### Main PCB as blackbox (only connector):

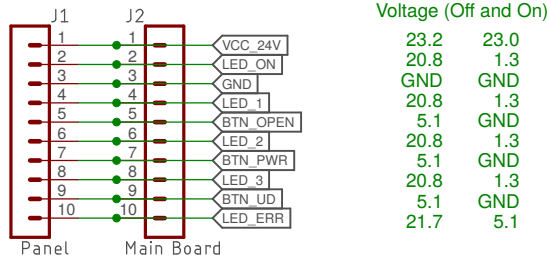

All pins of the connectors potentially carry 24V  
=> cannot directly feed into Arduino!

Turning the device on has no effect on the voltages of the LED and the BTN pins. A button press connects to GND, a burning LED causes the voltage to drop from 20.8V to 1.3V, except for the error LED, which drops from 21.7V to 5.1V when turned on.

As the LEDs and the button pins are not disabled when the device appears off, one can still flash the leds programmatically!

### Power Supply for Arduino / WeMos (5V) & NRF

A linear voltage regulator like the L78M05 gets too hot, so a step-down converter is required.

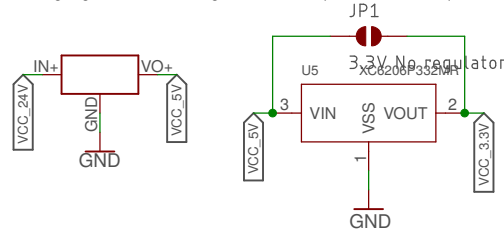

Alternatively, figure out a proper circuit to generate 3.3V  
=> need to adjust voltage dividers then!



open hardware

### Actuators: Emulate power On/Off button press, emulate UP button press, override error LED

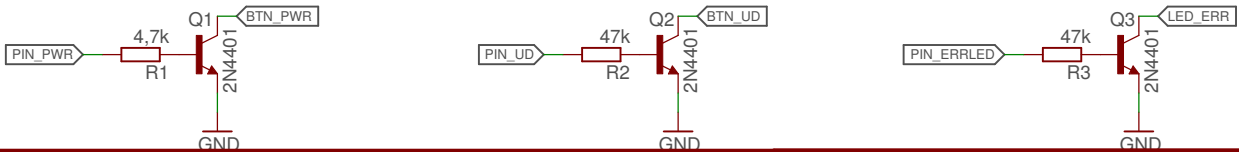

### Sensors: Detect if LEDs (Power, level, error) are on, check if case open sensor (button) is triggered

All Input pins (PIN\_1, PIN\_2, PIN\_3, PIN\_ON, PIN\_ERR and PIN\_OPEN) must enable internal pull-up resistors!

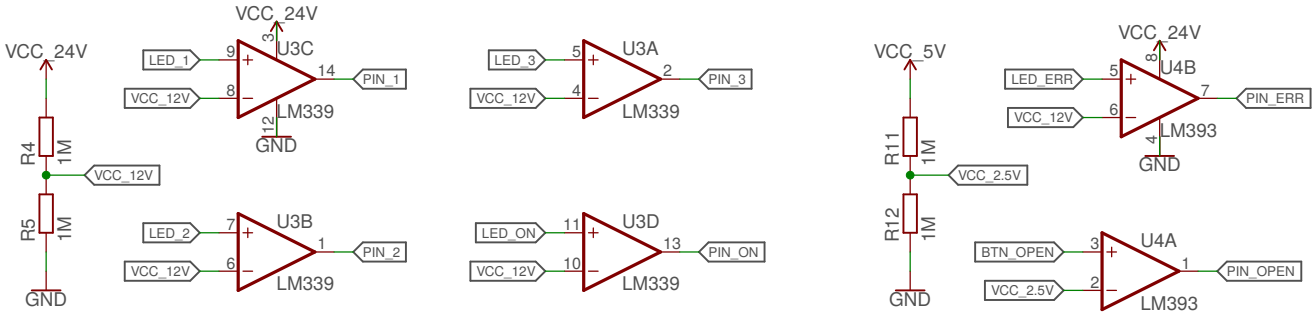

### Microcontroller: ATMEGA328P with external crystal

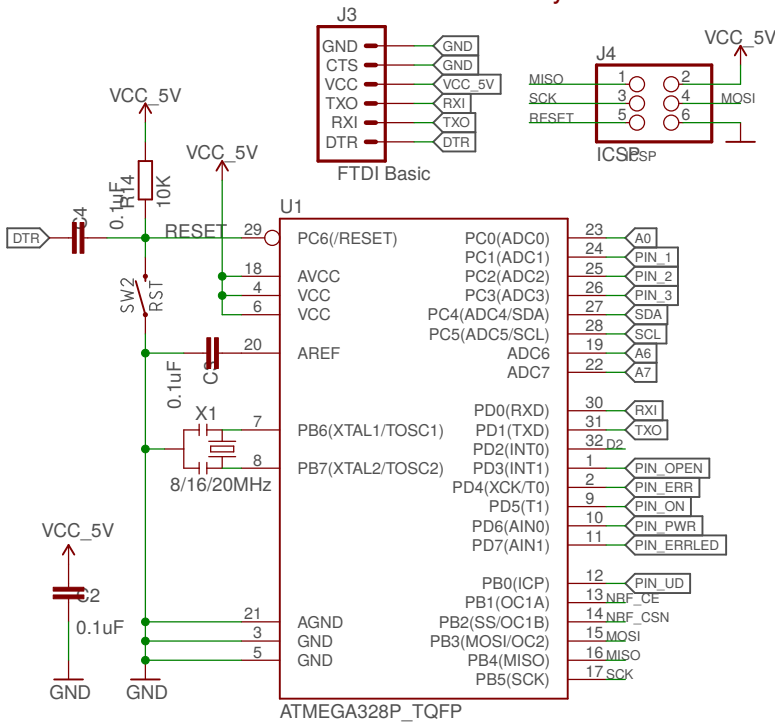

### MySensor-specific (NRF24L01+, signing)

